

OPERATIONS MANUAL

IM-3 SE 2000 UNDERPINNER



!!! For your safety !!!
Read the instructions manual carefully



INTRODUCTION

Congratulations upon your purchase of the INMES IM-3 SE 2000 USA Underpinner, designed to fill your needs for finishing and productivity!

The IM-3 SE 2000 USA Underpinner allows you to assemble frames of the size you want, using a full range of profiles. It applies a wedge in the back of the moulding, making a strong frame. The INMES "SW" wedge is designed to use in woods of normal density, and the "HW" wedge is for use with hard woods.

The IM-3 SE 2000 USA Underpinner has a mechanical action which eliminates, but does not significantly affect your productivity.

The IM-3 SE 2000 USA Underpinner comes to you ready to use, requiring only installation. Please read on so as to make the best use of your new equipment.

SPECIFICATIONS

- Weight _____ 50 lbs.
- Height _____ 45"
- Width _____ 15"
- Depth _____ 15"
- Widths of moulding _____ 3/8" - 4 3/4"
- Heights of moulding _____ 5/16" - 3 1/8"
- Wedge sizes _____ 7-10-12-15mm (1/4"-3/8"-1/2"-5/8")

Optional Accessories

- Large extender table
- "C" model pressure pad

Spare Parts included

- Small extender table
- 6mm Allen wrench
- 5mm Allen wrench
- 4mm Allen wrench
- 2.5mm Allen wrench
- Spare bolt with spacer for attaching machine to floor
- V-model pressure pad
- Magazine for 5mm and 7mm V-nails
- Magazine for 10mm V-nails
- Magazine for 12mm V-nails
- Magazine for 15mm V-nails
- Lubricant
- Manual

INSTALLATION

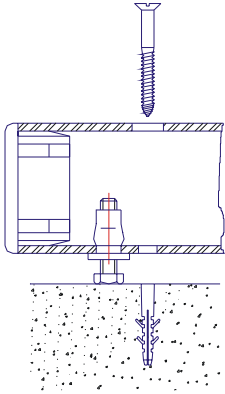

Fig. 01

OPERATION

1) Setting the stops for positioning wedges

The table of your machine has a scale (Fig. 02 Part 02) with measurements from zero to 3 1/4", that allows you to set the stops (Fig. 02 Part 05 and Fig. 02 Part 06), in this manner determining where the wedges will be inserted in the corners. The rear stop (Fig. 02 Part 05) determines the distance the wedge will be inserted from the outside of the frame. The distance setting between the rear stop (Fig. 02 Part 05) and the front stop (Fig. 02 Part 06) equals the distance between the outside and inside wedges.

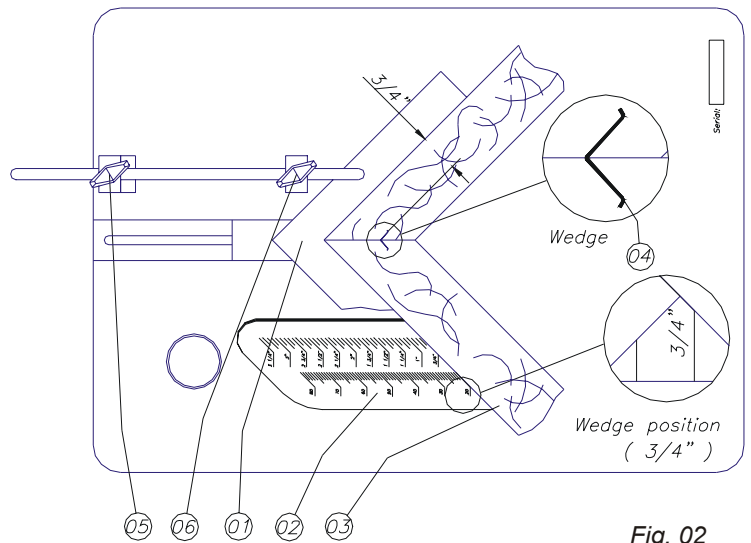

Fig. 02

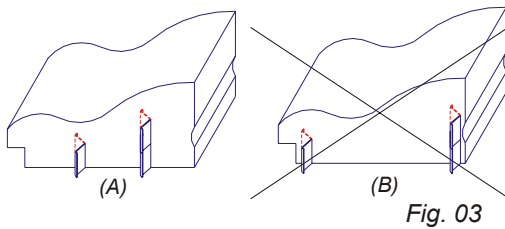

Fig. 03

If you want more wedges between the inside and outside ones, you will use your judgement in moving and stopping the slide guide as you move from the outside to the inside of the frame. Make sure the wedges are not placed too close to the edges of the moulding, so as not to split the material (Fig. 03).

2) Stacking wedges

If you want to stack the wedges in a particularly tall moulding, simply depress the foot-pedal twice, and two wedges will be inserted, one on top of the other (Fig. 04 and Fig. 05), or three times for a third wedge, etc.

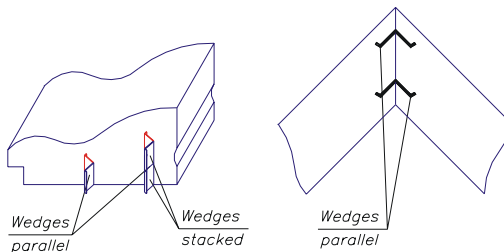

Fig. 04

Fig. 05

3) Select proper wedge size

After you have selected the moulding and frame size, you can determine what size wedge and how many you want to use on each corner. You want to get the most rigidity possible to allow your glue to set. Make sure the wedge is not so tall as to damage the moulding by coming through the top (Fig. 06).

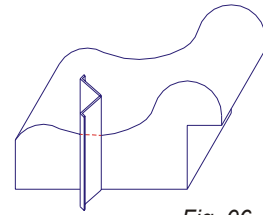

Fig. 06

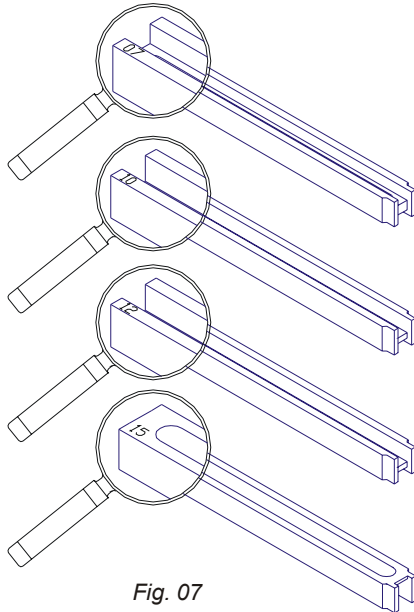

Fig. 07

4) Select the proper magazine size

Select the magazine size according to the size of wedge you will be using. The side of the magazine has a number on it which indicates which size wedge it takes (Fig. 07).

Important: The 7mm magazine has "7mm" marked on one side, for the 7mm wedges, and "5mm" marked on the other side, which takes the 5mm wedges.

5) Load the empty magazine into the machine

Pull back on the spring-loaded cable (Fig. 08 Part 03), which allows you to slip the empty magazine into its slot (Fig. 08 Part 02) in the table. Remember that the side facing up should have the number indicating the size wedge (in millimeters) stamped on it.

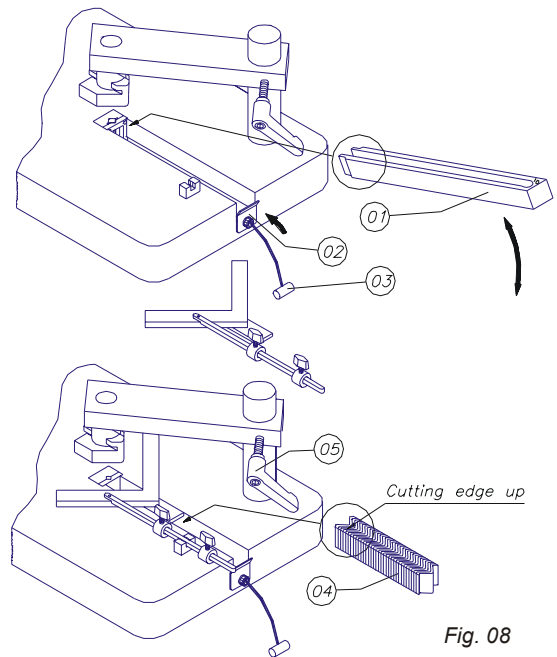

Fig. 08

6) Load the V-nails into the magazine

Pull back on the cable again, and from the point of view of the side of the table where the spring-loaded cable (Fig. 08 Part 03) is located (the back), put the wedges (Fig. 08 Part 04) in the magazine (Fig. 08 Part 01) with the cutting side (the side with the glue) facing up, and with the open end of the "V" facing away from you, towards the front of the table. Release the cable so that the spring pushes the shoe against the wedges, feeding them into the head as they are used.

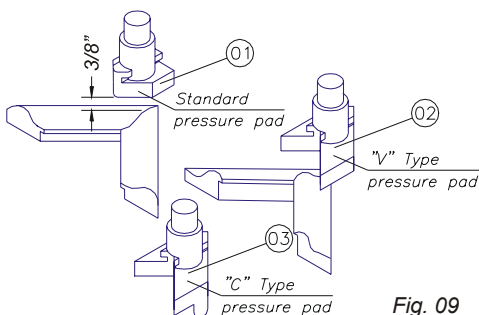

Fig. 09

8) Set the position of the pressure pad

The height of the pressure pad (Fig.09 Part 01) should be adjusted according to the moulding's height, using the adjusting handle (Fig. 08 Part 05). Pull the handle outwards and turn it counterclockwise to loosen the pad's arm. The pad should be set 3/8" above the top of the moulding, as shown in Fig. 09. Then tighten the pad's arm by turning the handle clockwise. The handle is springloaded and allows you to leave it in the position convenient to you when you release it.

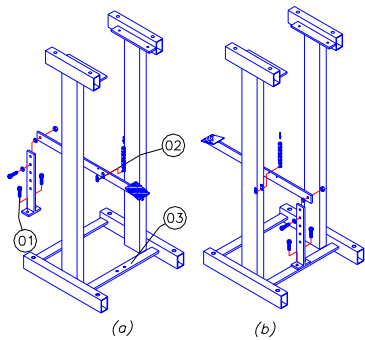

Fig. 10

7) Reversing position for large mouldings

When making large frames, you may find it convenient to work from the back side of the machine, using extender tables (available accessories) to support the moulding pieces. You only need to move the position of the foot pedal from the front to the back of the machine.

When using "reverse" moulding profiles, when the moulding rabbet on the inside of the frame is taller than the outside, you should substitute the regular pressure pad with the "V" or "C" model pressure pads, shown in Fig. 09. The V-shaped pad is more flexible. They will not damage this type of moulding, as well as giving more support and assuring a good seating of the wedge.

9) Eye protection

The clear acrylic hand and eye protector (Fig. 11 Part 02) should be adjusted so that its bottom edge is level with the bottom of the pressure pad (Fig. 11 Part 03). You may do this by using the butterfly bolts (Fig. 11 part 01) on either side of the protector. **KEEP HANDS CLEAR OF PRESSURE PAD!**

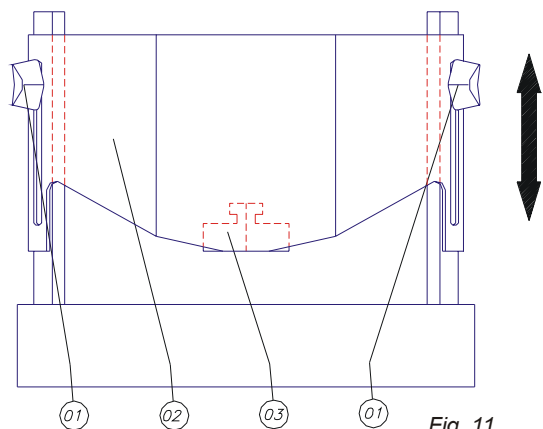

Fig. 11

MAINTENENCE

- 1) **Lubrication** - All moving parts should be lubricated after every 40 hours of machine use. A lubricant comes with the machine.
- 2) **Location** - The Underpinner should be protected from weather, humidity, dust, etc.

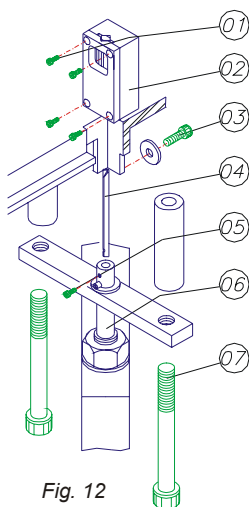

Fig. 12

- 3) **Replacing the nail driver rod** - If the drive rod (Fig. 12 Part 04) breaks, replace it by following the following procedure:

Remove bolt (Fig. 12 part 03), and pull the assembly head up through the top of the table. Then remove the head screws (Fig. 12 part 01) and pull out the drive rod (Fig. 12 Part 04). Place the new one in the head, with the hole at the bottom to receive bolt (Fig. 12 Part 03). Put a drop of sewing machine oil on the drive rod before reassembling. After reassembling, make sure the drive rod moves freely up and down. When putting the head back on the machine, be sure it is level with the top of the table, and that the drive rod continues to move freely. You may do this by operating without wedges, and with the pressure pad rotated off to one side. **Keep hands away from pad!**

- 4) **Cleaning** -

- a) **The pressure pad** (Fig. 09), should be cleaned periodically with warm water, no soap, in order to remove the glue applied to the joints of the frames.
- b) **The slot** where the wedge comes up through the table should always be kept clean, as should the entire table top. Dried glue should be removed with warm water, never scraped off.
- c) **The drive assembly** - Periodically you should clean the drive assembly head. Proceed as described above to replace the assembly. Wash with warm water, wipe thoroughly, then put a drop of sewing machine oil on the drive rod before reassembling. **Remember to keep hands away from pad when testing!** If the drive rod does not come out easily, do not beat it with a hammer.

TROUBLESHOOTING

Drive rod stuck - This can happen if:

- a) Residues /dirt have gotten into the driver head assembly causing the drive rod to stick after it pushed up the wedge, not returning to its original position.
- b) The wedges were placed in the cartridge upside down, i.e. with the glue side down. The glue side of the wedges is the cutting edge, and must face up. If the wedges are placed glue side down, instead of the drive rod pushing against the base of the wedge, the bevel on the cutting edge will act as a guide that directs the drive rod along the side of the wedge, causing the rod to get stuck, since it and the wedge are occupying the space designed for the drive rod alone.

To release the drive rod, simply pull down on the air cylinder. This will pull back the drive rod to its original position. Then make sure that the wedges have the glue side facing up in the cartridge. If they are in the proper position, you should clean the drive head assembly. If you cannot pull the air cylinder down, you should then perform the procedure described in paragraph 3 in the Maintenance section of this manual.

PARTS LIST FOR IM-3P SE

CODE	DESCRIPTION	CODE	DESCRIPTION
0301003	Base for positioning stops	0302249	Washer for driver head screw
0301005	Bushing	0403002	Polyurethane pressure pad
0301006	Bushing	0403003	Plastic foot
0301008	Bushing	0405120	Label
0301010	Pressure drive shoe	0408005	Bolt M3x16mm
0301011	Guide bar for wedge spring loader	0408008	Bolt M4x16mm
0301013	Nut M16	0408009	Bolt M4x20mm
0301014	Chain's protector	0408010	Bolt M4x25mm
0301015	Chain's guide	0408012	Bolt M5x8mm
0301017	Guide shaft for drive assembly	0408016	Bolt M6x16mm
0301020	Foot pedal support	0408018	Bolt M6x20mm
0301022	Down support arm	0408026	Bolt M8x20mm
0301026	Upper support arm	0408026	Bolt M8x25mm
0301028	Position stop	0408030	Bolt M8x40mm
0301029	Spring-loaded cable shoe plate	0408045	Bolt M10x80mm
0301030	Wedge shoe	0408113	Bolt M4x12mm
0301031	Magazine for 7mm wedges	0408140	Bolt Hex. M8x25mm
0301032	Magazine for 10mm wedges	0408144	Steel Rivet 3,2x10,2mm
0301033	Magazine for 15mm wedges	0408160	Nut M4
0301038	Bolt M5	0408179	Nut M8
0301040	Foot pedal	0408201	Washer 5/16"
0301043	Shaft	0414003	Chain
0301045	Aluminum table top	0415003	Butterfly screw
0301051	Spring-loaded cable	0415004	Butterfly screw
0301054	Main Shaft washer	0416002	Spring
0301056	Pressure pad adjustment handle	0416002	Spring
0301060	Anti-Sliding sticker	0417008	Flex pin
0301072	Eye protector guide	0417009	Flex pin
0301073	Acrylic eye protector	0417010	Flex pin
0301079	Magazine for 12mm wedges	0417011	Flex pin
0301080	Base leg	0417012	Bushing
0301081	Moulding guide and Teflon pad	0419090	Table top calibrated sticker
0301087	Guide for drive piston	0504015	Label
0301089	Drive rod		ACCESSORIES
0301102	Driver head assembly	0408074	Allen wrench 2.5mm
0301129	Bushing	0408139	Allen wrench 4.0mm
0301130	Bolt	0408075	Allen wrench 5.0mm
0301132	Main shaft	0408076	Allen wrench 6.0mm

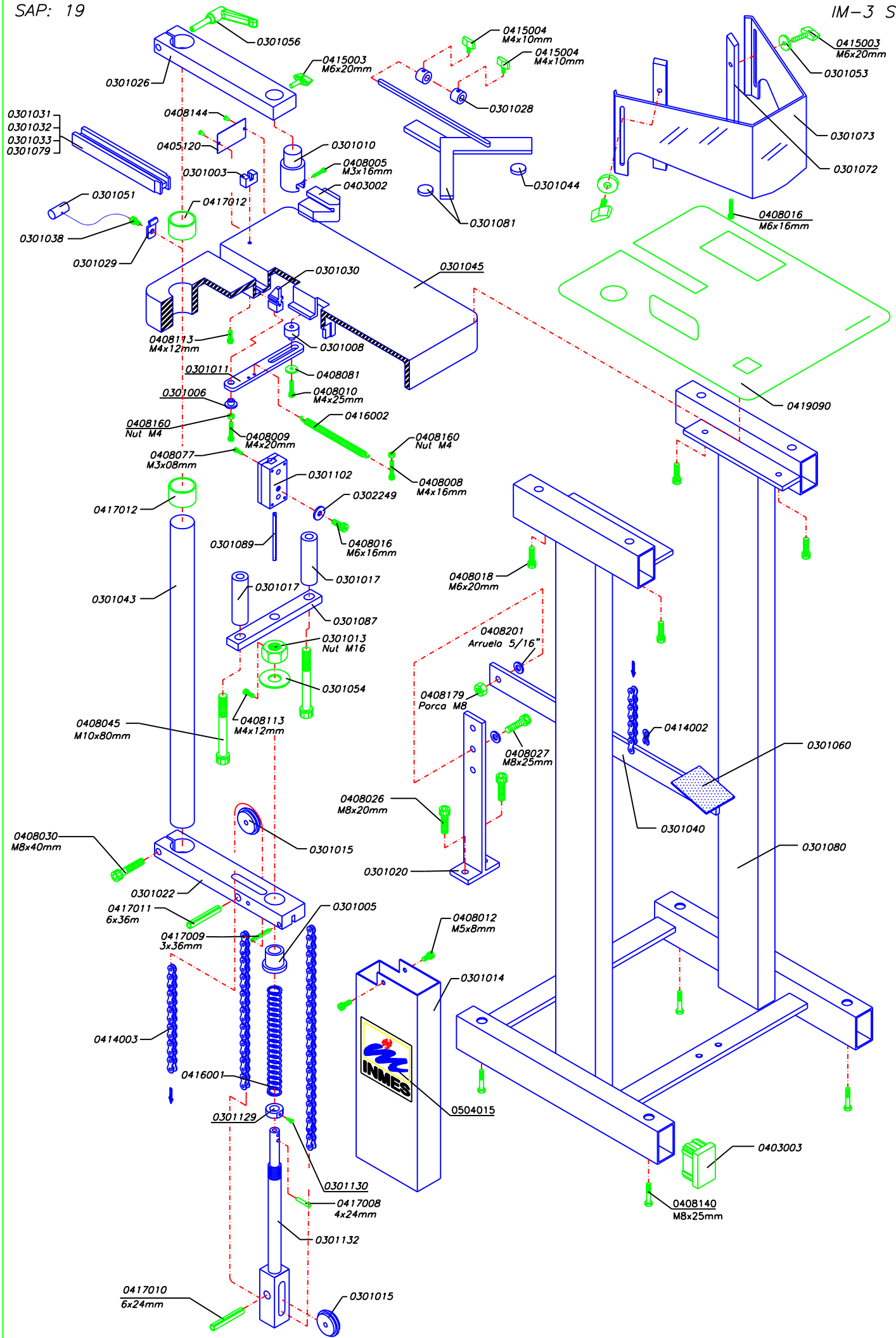

Samples of frames you can assembly with the IM-3 SE 2000 underpinner, when you have the accessories contact the distributor near you!

Accessories code

- 0301001 to hexagonal frames
- 0301002 to octagonal frames
- 0301085 to 18 sides frames
- 0301086 to 12 sides frames

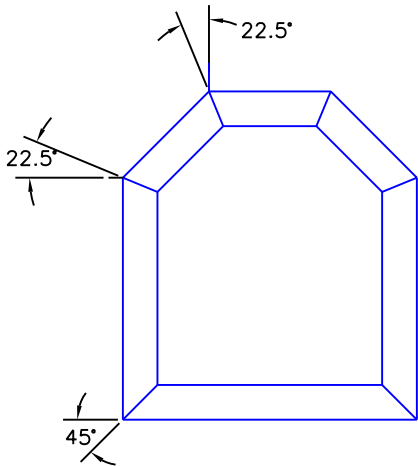

Octagonal - square

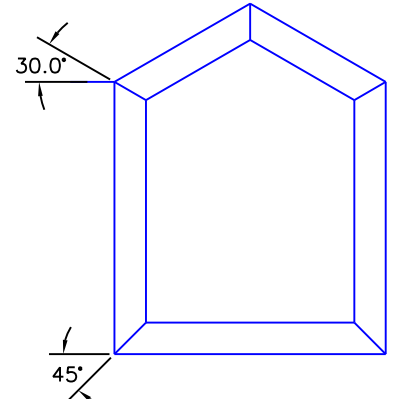

Hexagonal - square

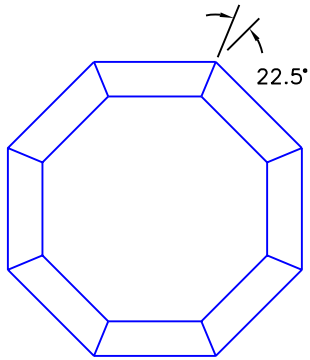

Octagonal

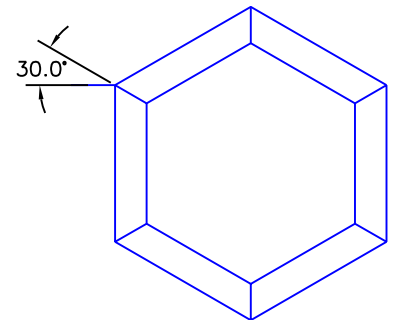

Hexagonal

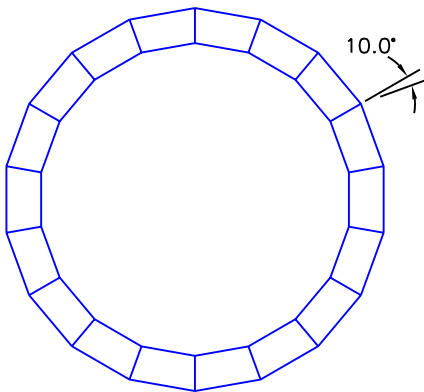

18 Sides

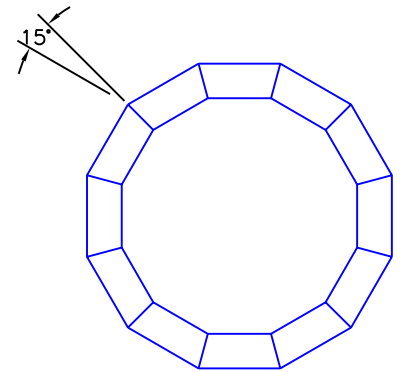

12 Sides

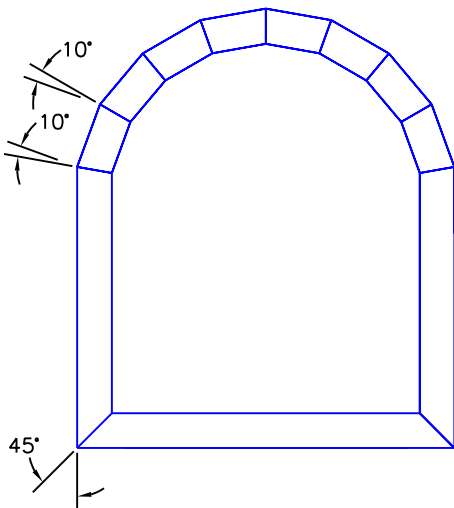

18 Sides - square

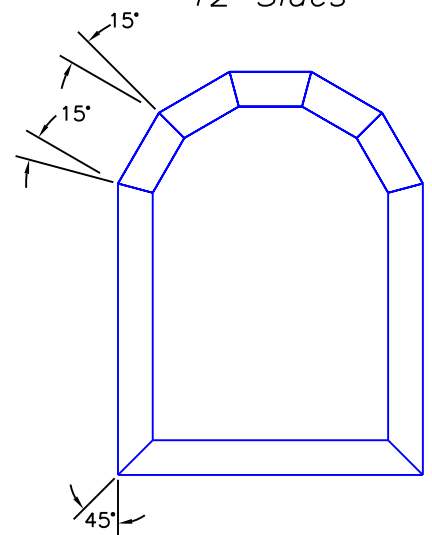

12 Sides - square